

Bolted Joints An Interactive Software

H.A. Bogis, A.AbouEzz, A.A. Aljinaidi and M. Akyurt

Mechanical Engineering Dept., KAAU, Jeddah 21589

Correspondence: makyurt@kaau.edu.sa

ABSTRACT. An educational software; *Bolted joints*, is presented for the analysis and design of screwed or bolted connections. The user starts the application by specifying his objective. Next, he proceeds to the description of the geometry of the joint by specifying the material and thickness of the members to be jointed, the washer and the gasket, in case the latter two are required.

The loads may be in the form of axial or transverse loads, or a combination of them. The user specifies coefficients of friction and the type of connection, indicating whether it is of the through bolt type or a stud type of connection, and selects the materials for the bolt, washer and the members that are being jointed.

The software presents a *report* comprising a summary of stresses, stiffnesses and factors of safety, and detailed summary of the fastener geometry and properties.

1. Introduction

A screwed or bolted connection is mainly composed of two main elements, i.e., bolt and nut, in addition to the parts that are being bolted together. Bolted connections are widely used where parts are to be readily connected or disconnected without damage. Screwed connections are economical and highly reliable. The main disadvantage of screwed joints is the stress concentration in the threaded portions.

Current research activity on bolted joints seems to be concentrated on modeling (2 and 3-D finite elements), fatigue studies, corrosion, high-temperature creep, cracking, degradation due to irradiation and notch sensitivity. The subject of flanges and gaskets attracts much attention as well as bolted joints involving composite materials.

A bolted joint is subjected to high stress concentrations at the thread root because of the complicated geometry. Plastic regions are produced around the bottom of thread root, even under relatively low bolt axial forces. It may be predicted that plastic deformations thus produced may affect the load distribution along threads, and the relationship between bolt axial force and angle of nut rotation. In many practical applications, bolts are tightened with considerably high clamping forces. When tightening bolted joints with torque control, shear stresses are generated in addition to tensile stresses due to the bolt clamping force. Fukuoka and Takaki [1] studied the mechanical behavior of bolted joints during tightening with torque control. The authors used FEM and treated the case as a 3-D elasto-plastic contact problem.

Experimental studies were conducted by Zhao and associates [2] on the effects of various factors on looseness behavior of side mounted stabilizer bar attachment bolts. Among all the influence factors studied, four factors were identified as the most important ones. By controlling these factors and optimizing the mounting configuration, the problems caused by bolt looseness could be reduced. It was found that the relation of the dropping clamping force versus the number of load cycles could be described by a logarithm equation. A criterion was proposed to identify whether bolt looseness takes place. Based on the logarithm equation, it was possible to predict the clamping force of a bolt in service.

Yang and DeWolf [3] noted that, during a recent bridge construction, galvanized coating thickness on bolts were in excess of 12 mils. Since thicker coatings on steel can reduce shear capacity in high-strength bolted connections, there was concern that the thick galvanized coating could compromise bolt performance. The authors conducted a study to investigate the relaxation and the shear capacity of high-strength bolted connections with galvanized coating thicknesses up to 20 mils. Both normal and oversize holes were studied. The research showed that the shear capacity of connections with thick galvanized coatings is reduced due to the loss in the clamping force.

Sergeev et al [4] studied the effect of bolt spacing and degree of anisotropy on the bolt load distribution and nature of the failure mechanism. Bolt loads and failure prediction were determined using a solution method that treats the contact stresses and contact region as unknowns. Utilizing the boundary collocation technique, this method provides the non-linear solution while capturing the effects of finite geometry under general loading conditions. The nature of the failure mechanism was established by using the maximum strain criterion. Comparison of the predictions with experimental results revealed close agreement.

Ellis and Tordonato [5] reported on the development of analytical life prediction methods for high temperature turbine and valve studs/bolts. In order to validate the approach, the calculated results were compared to the results of uniaxial stress relaxation testing, bolt model testing and service experience. Long time creep, creep-rupture and stress relaxation tests were performed by the National Research Institute for Metals of Japan (NRIM) for 12Cr -1Mo -1W- 1/4V, Type 422 stainless steel bolting material, at 500C, 550C and 600C. Based on these results and limited tests for a service exposed bolt, the creep behavior was described using a two-parameter material model. For comparison with the measured uniaxial stress relaxation properties, the stress relaxation was calculated using the two-parameter creep equation and a strain hardening flow rule. The rupture time data was correlated using time-temperature parameter methods. A power law was used for the rupture strain versus rupture time relationship at each temperature. The calculated stress versus time curves were in good agreement with the measured at all temperatures and for initial strain levels of 0.10%, 0.15%, 0.20% and 0.25%.

In steel construction, sometimes bolts and welds must be combined in a single joint. Manuel and Kulak [6] observed that provisions for the design of these combination joints can be found in existing specifications, but the design rules generally have not been verified by physical tests. An experimental study using full-scale tension lap splices that combined high-strength bolts and fillet welds was carried out in order to develop a better understanding of combination joints. The results showed that the orientation of the welds and the bearing condition of the bolts are two key factors that must be considered when determining the extent of load sharing in combination joints.

Ma and associates [7] presented a technique for identifying the dynamics of bolted joints. The technique relies on the comparison of the overall dynamics of the bolted structure to that of a similar but unbolted one. The difference in the dynamics of the two systems can be attributed solely to the joint; modeling this difference in the dynamics enables us to construct a nonparametric model for the joint dynamics. Noncontacting, laser vibrometry was utilized to experimentally measure the structural responses with increased accuracy and to perform scans of the structural modes at fixed frequency. A numerical algorithm was then developed to post-process the experimental data and identify the joint force. Theoretical calculations were first used to validate the technique, which was then utilized to identify a practical joint. Experimental force-displacement plots at the joint revealed clear hysteresis loops which, in turn, can be used to estimate the damping dissipation at the joint. Moreover, experimental frequency responses and scans of the mode shapes of the bolted structure revealed nonproportional damping and nonlinear effects due to micro-impacts of the connected beams at the bolted joint.

Gaul and Nitsche [8] remarked that friction damping in bolted joint connections of large space structures may be a major source of damping. For vibration suppression, the joints were designed such that the normal force in a frictional interface is controlled which improved the damping performance. The use of active control to vary the normal contact force in a joint by means of a piezoelectric element was explored. A model consisting of two elastic beams connected by a single active joint was considered. A friction model with velocity-dependent dynamics was used to describe the friction phenomena. A control law for friction dampers which maximises energy dissipation instantaneously by controlling the normal force at the friction interface was proposed.

Calado and associates [9] studied the structural response of typical semi-rigid steel beam-to-column joints. In particular, the behaviour of bolted cleat angle connections was investigated under different loading conditions, both monotonic and cyclic loading being considered. 15 full-scale tests were carried out by comparing the performance of specimens with reference to three different sizes of column member as well. Outcomes showed that the main sources of inelastic deformation are located in cleat angles, which constitute the most influential component. As a consequence, the column size has a limited effect on the whole hysteretic response of the joint.

The design of bolted connections involves considerations for initial tensioning of the bolt, fatigue effects, the clamping effect, bending effects due to eccentric loadings, and the effects of washers and gaskets. The *Bolted Joints* software that is introduced below is part of a larger educational software package [10, 11, 12] that is being developed by the authors. *Bolted Joints* is expected to be of major assistance to students and design engineers during the analysis and design of static screw connections.

2. The Bolted Joints Package

Figure (1) shows the icon of *Bolted Joints*. When this icon is clicked, the user accesses the main screen (Fig. 2) of the software which enables the analysis and design of screwed connections.



Fig. (1) : The icon of *Bolted Connections*.

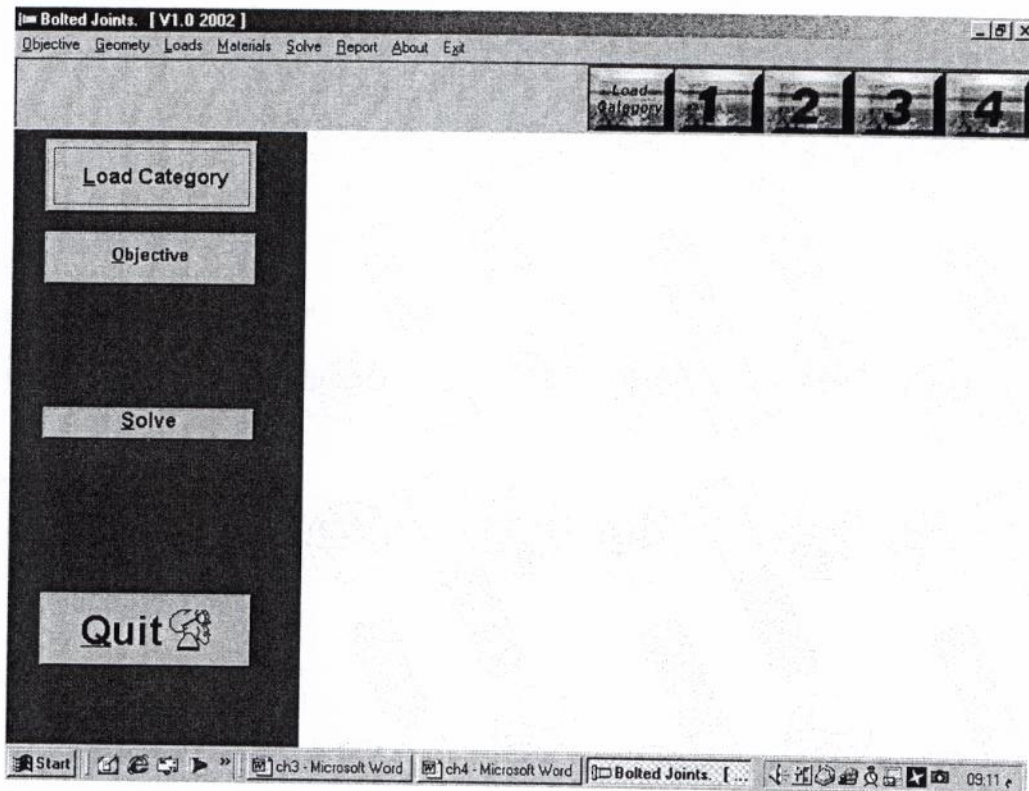

Fig. (2) : The main screen of *Bolted Connections*.

Lined horizontally at the top of the mainscreen are the prompts *Objective*, *Geometry*, *Loads*, *Materials*, *Solve*, *Report*, *About* and *Exit*. Several of these are repeated in a contact-sensitive format as separate buttons lined vertically down the left side of the screen, along with the *Load Category* button. The latter is presented also in the form of four numbered buttons, and displayed across the screen in a colorful fashion.

When either the *Objective* prompt or the *Objective* button is clicked, the screen of Fig. (3) pops up, whereby the user opts either to find the *Safety Factor* for an existing bolted joint, or to find the *bolt diameter* in a new design.

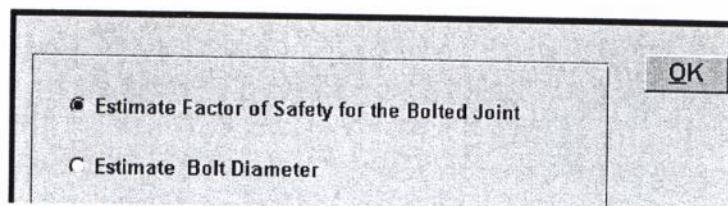

Fig. (3) : Selection of the *objective*.

2.1 Axial Loading

Once the *objective* is defined, the next logical step would be to define the *load category*. Thus moving the mouse over the button numbered 1 causes the screen of Fig. (4) to appear. Clicking on the said button reveals the screen of Fig. (4a), where information regarding joint geometry, fastener type and initial tightening can be supplied.

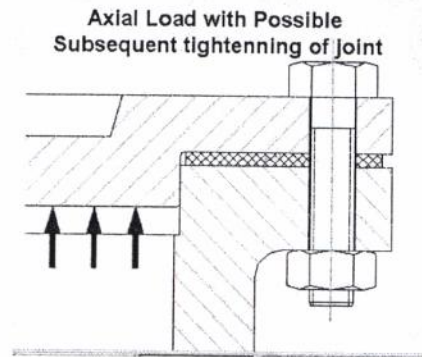

Fig. (4) : Symbol for load category #1.

Joint Geometry	Initial Tightening	Fastener Type
All Dimensions in mms.		
Bolt Diameter : 5		Material
The First Member Thickness :	<input type="text"/>	Material E = 207 GPa
The Second Member Thickness :	<input type="text"/>	Material E = 207 GPa
Washer Thickness :	<input type="text"/>	Material E = 207 GPa

Fig. (4a) : Specification of *joint geometry* for loading category #1.

Notice in Fig. (4a) that a bolt diameter of 5 mm is initially assumed. Clicking on the associated button, it is possible to select from a list of choices and to specify a material each for the bolt (Fig. 4b), the first and second members being joined, as well as the washer (Fig. 4c). The individual thickness of each of the last three items can be also entered at this stage.

Clicking on *Initial Tightening* (Fig. 4a) next, the screen of Fig. (4d) is presented to the user. Here the user can opt for a *permanent joint* or a *re-useable joint*. He is given the opportunity to specify a *diameter* and a *pitch* for the bolt, which action influences the necessary *initial tightening force*, the *tightening torque* and the *% of proof stress*. The designer can also indicate whether the metric thread is to be *course* or *fine*. He further specifies the *external load* acting on the bolt, and the *coefficients of friction*.

Min Ultimate Tensile Strength	400 MPa
Min Yield Strength	240 MPa
Min Proof Strength	225 MPa
Factor of Safety	1

Fig. (4b) : Selection of the material for the bolt.

Fig. (4c) : Specification of material for the first and second members.

Initial Tightening

Reused Joint Perminant Joint

Initial Tightening Force (KN):

Initial Tightening Torque (N.m):

Z Proof Stress:

Torque Factor:

Bolt Dimensions

Diameter: Pitch:

Bolt Thread Type

Metric Coarse-Pitch Threads
 Metric Fine-Pitch Threads

Bolt External Applied Load: N

Thread Friction Coefficient:

Bolt Head Friction Coefficient:

Fig. (4d) : The screen for *Initial Tightening*.

When the user clicks on the *fastener type* button in Fig. (4a), the screen of Fig. (4e) pops up. Here the user selects between a *through bolt* connection and a *tap bolt* connection. He further specifies if a *gasket* is used, or that the sealing at the joint is provided possibly by an O-ring, which is essentially the same as having *no gasket*.

With all necessary information already entered, we are now ready to solve the design problem by invoking the *Solve* button on the screen of Fig. (2). Figure (4f) shows the screen that pops up when the factor of safety is less than one, and hence the bolt connection has failed. Figure (4g) shows the output screen for a successful design.

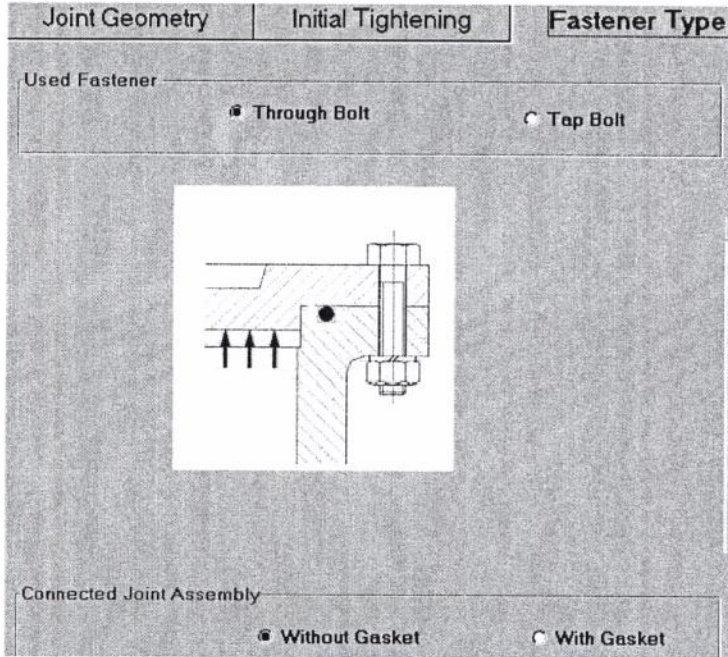

Fig. (4e) : The screen for the *Fastener Type*.

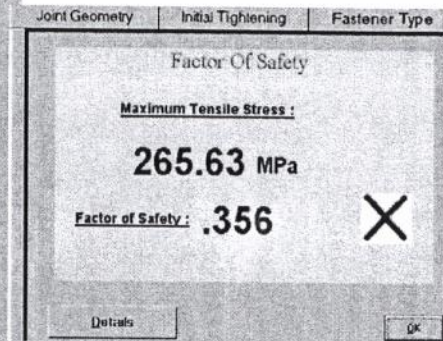

Fig. (4f) : The bolt connection has failed.

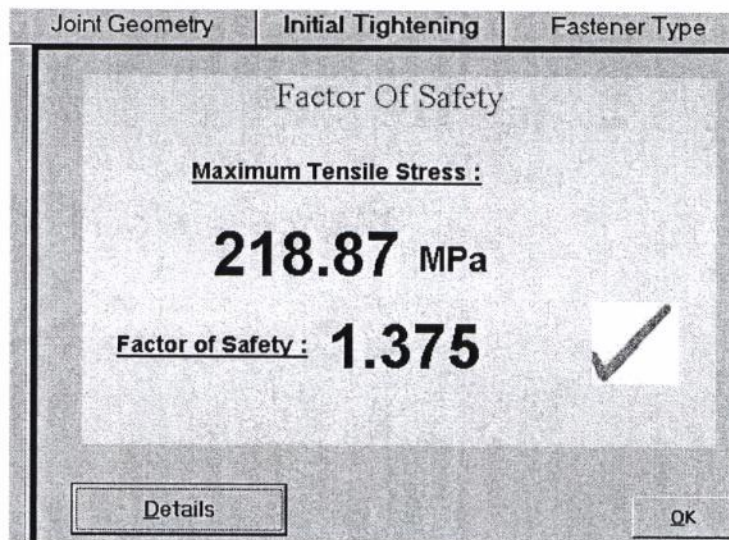

Fig. (4g) : The bolt connection is successful.

Clicking on the *Details* button in Figs. (4f) or (4g) results in the displaying of information for the current state of the stresses on the threads on the bolt as well as on the nut (Fig. 4h). Opting for *Fastener Geometry* in the *Results Report* causes the screen of Fig. (4i) to be displayed, where all pertinent design details about the fastener are summarized. Invoking the *Initial Tightening* button in the *Results Report* brings forth the colorful screen of Fig. (4j), where the proof stress of the joint is tabulated along with the probability that one or more of

the bolts will be *over-proof loaded*. The *torque-wrench setting* is displayed prominently, along with other pertinent design data. The type of joint is declared graphically in force versus extension graph, and the force applied at the joint is clearly marked on the graph.

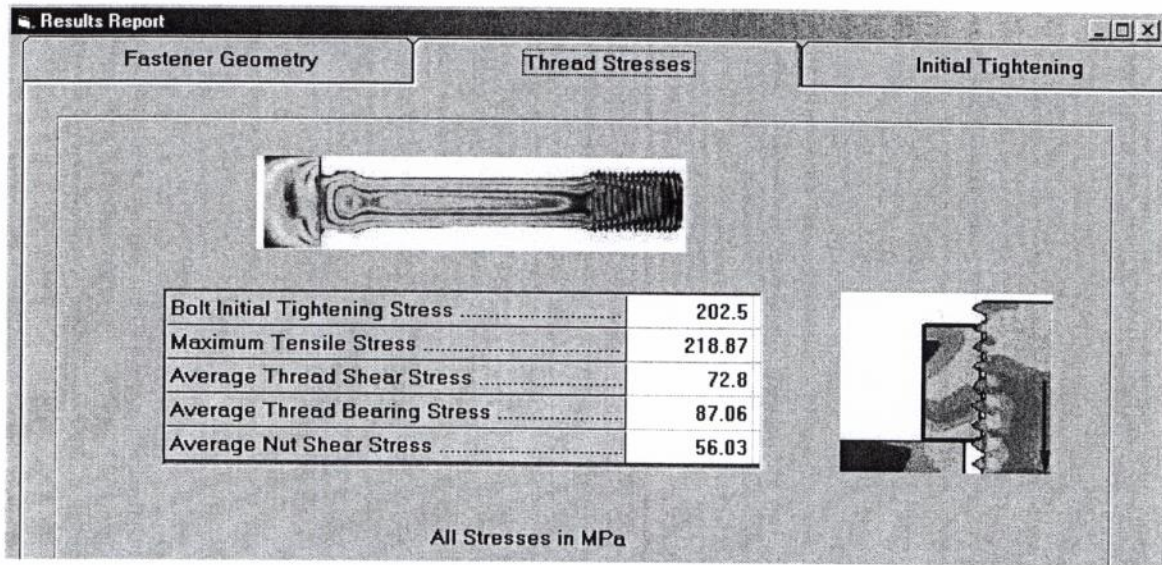

Fig. (4h) : Details of the results on *thread stresses*.

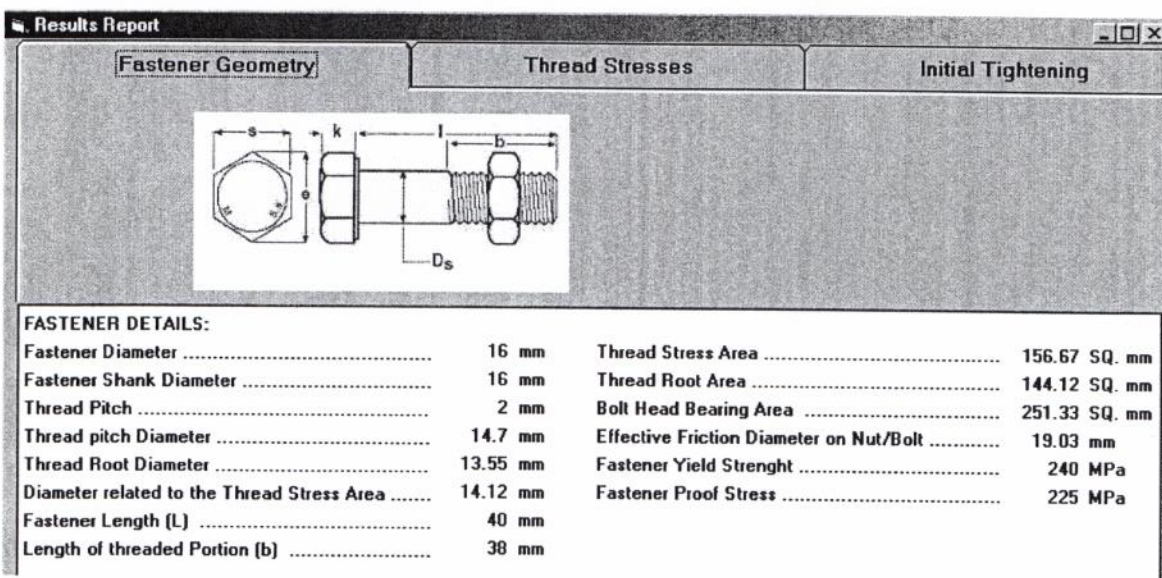

Fig. (4i) : Details of the results on *geometry of the fastener*.

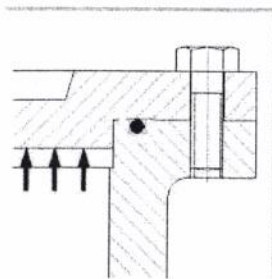

Fig. (4k) : A *tap bolt*.

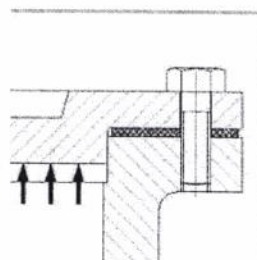

Fig. (4l) A *tap bolt joint with a gasket*.

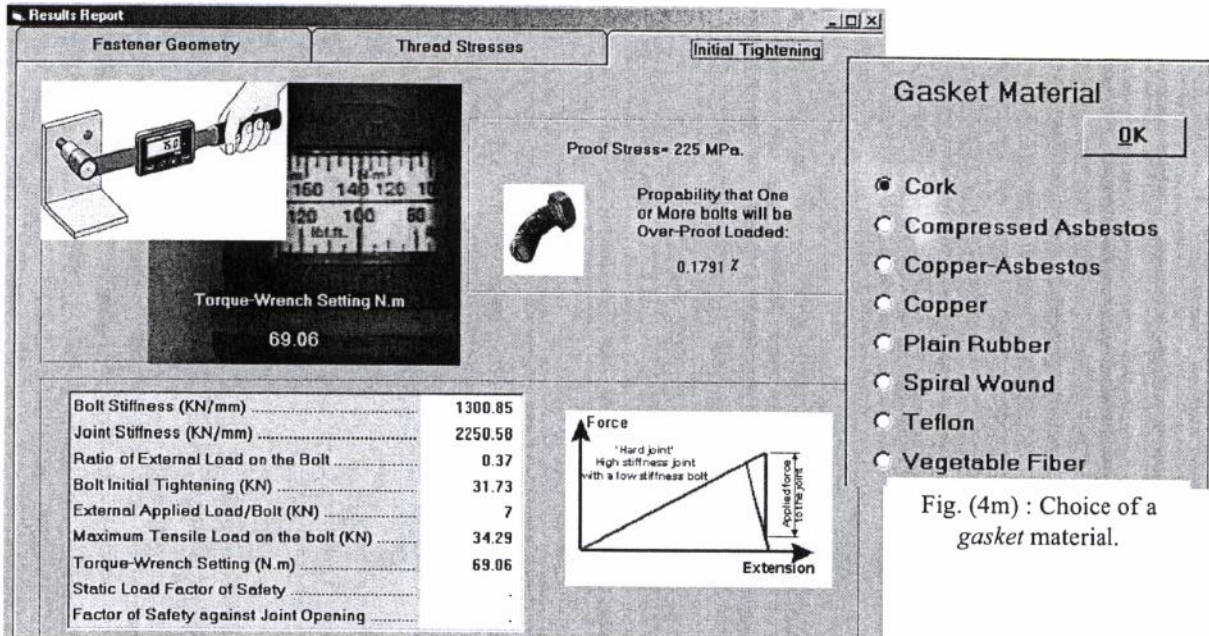

Fig. (4j) : Details of the results on Initial Tightening.

If in Fig. (4e) the choice was made for a *tap bolt* instead of a *through bolt*, the central picture of Fig. (4e) would be replaced by the sketch of Fig. (4k). In similar manner, if *with gasket* is the choice in Fig. (4e), the sketch is further modified to that of Fig. (4l). In the latter case the screen of Fig. (4a) would have provision for the thickness and material of the gasket, as indicated in Fig. (4m), where the elastic modulus of the selected material is also listed.

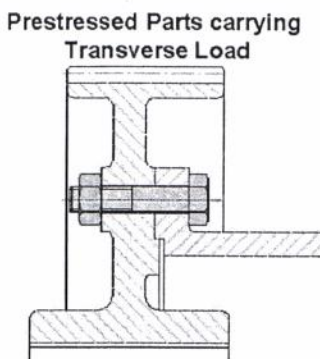
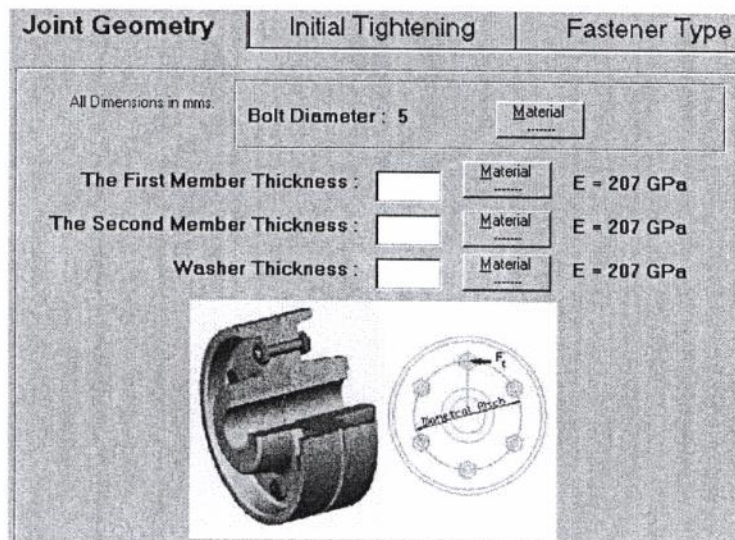

Fig. (5) : The main screen for transverse loading.



2.2 Transverse Loading

Moving the mouse over the button for *Loading Type 2* on the main screen of Fig. (2) causes the displaying of the screen for *transverse loading with prestressing* (Fig. 5). Clicking now on button #2 pops open the screen of Fig. (5a), which is analogous to the screen of Fig. (4a), the difference being essentially in the replacement of the drawing in Fig. (4a) by that of a coupling.

It is to be noticed in Fig. (5a) that a bolt diameter of 5 mm is initially assumed. Clicking on the associated button, it is possible to select from a list of choices and to specify a material each for the bolt, the first and second members being joined, as well as the washer. The individual thickness of each of the last three items can be also entered at this stage.

Joint Geometry	Initial Tightening	Fastener Type
		
Bolt Head Friction Coefficient: <input type="text" value="0.1"/>		Number of Bolts: <input type="text" value="2"/>
Required Initial Tightening Force (KN): <input type="text"/>		
<input checked="" type="radio"/> Ft <input type="radio"/> Mt, R <input type="radio"/> Power, w, R		Tangential Force Per Bolt: <input type="text" value="2000"/> KN

Fig. (5b) : The specification of *fastener type*.

The specification of *joint geometry* and *initial tightening* are done in a manner that is analogous to the case of *load type # 1*.

As for the specification of *fastener type*, the screen of Fig. (5b) pops up when the button for this item is invoked. The user is given an opportunity to specify the *coefficient of friction* as well as the *number of bolts* used in the assembly. The *required initial tensioning* is another entry. The user is further prompted to make a choice between *Ft*, *Mt, R* and *Power, w, R*. Thus if tangential force *Ft* is the choice, and he must specify the *tangential force per bolt*, as indicated in Fig. (5b). In case the user wishes to specify the *moment Mt* and the *radius of the pitch circle, R*, then he is prompted to provide this information, as shown in Fig. (5c).

<input type="radio"/> Ft <input checked="" type="radio"/> Mt, R <input type="radio"/> Power, w, R	Torque (N.m) <input type="text"/>
	Pitch Circle Radius (mm) <input type="text"/>

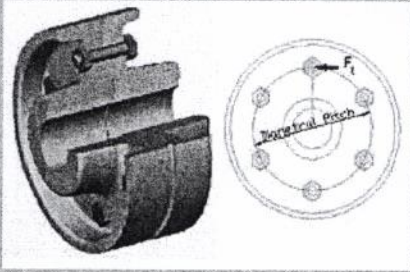
Fig. (5c) : Specification of *MT* and *R*.

<input type="radio"/> Ft	Power (Kw)	<input type="text"/>
<input type="radio"/> Mt R	Angular speed (rpm)	<input type="text"/>
<input checked="" type="radio"/> Power, w, R	Pitch Circle Radius (mm)	<input type="text"/>

Fig. (5d) : The specification of *Power*, *w* and *R*.

The last choice in the specification of transverse loading is that of specifying the *power* transmitted through the joint, the angular velocity *w*, and the *radius of the pitch circle*, *R*, as illustrated in Fig. (5d).

Once the input data is complete, one then proceeds with the solution. The output format and the *Result Report* is in exactly the same format as detailed in Figs. (4f to 4j).

2.3 Axial Loading

Moving the mouse over the button for *Loading Type 3* on the main screen of Fig. (2) causes the displaying of the screen for *axial loading only* Fig. (6). Clicking now on button #3 pops open the screen of Fig. (6a), which is a combined screen. Clicking on the *material* button causes the appearance of the screen of Fig. (4b) for selection of the bolt material. After specifying the rest of the information on Fig. (6a), the user is now ready to invoke the *solve* button. The output format and the *Result Report* is in exactly the same format as detailed in Figs. (4f to 4j).

Parts carry Axial Load Only

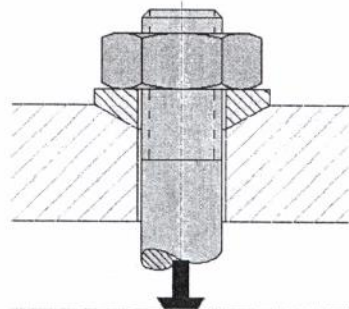

Fig. (6) : The main screen for axial loading.

2.4 Axial Loading with Subsequent Tightening

Moving the mouse over the button for *Loading Type 4* on the main screen of Fig. (2) causes the displaying of the screen for *axial loading with subsequent tightening* Fig. (7). Clicking now on button #4 pops open the screen of Fig. (7a), which is a combined screen. Clicking on the *material* button causes the appearance of the screen of Fig. (4b) for selection of the bolt material. After specifying the rest of the information on Fig. (7a), the user is now ready to invoke the *solve* button. The output format and the *Result Report* is in exactly the same format as detailed in Figs. (4f to 4j).

Fig. (6a) : Input screen for the case of purely axial loading.

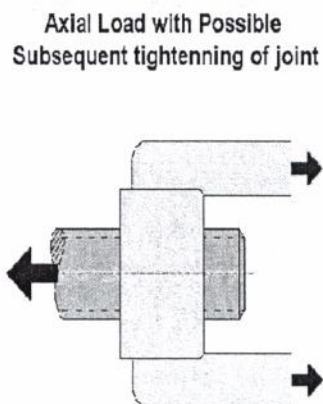

Fig. (7) : The main screen for axial loading with subsequent tightening.

3. Concluding Remarks

Bolts is a user-friendly and yet powerful tool for the analysis and design of bolted joints. The user starts the application by specifying his *objective* as either finding the *safety factor* for an existing bolted joint, or to determine the *bolt diameter* in a new design. Next he proceeds to the description of the *geometry* of the joint by specifying the *material* and *thicknesses of members to be joined*, the *washer* and the *gasket*, in case the latter two are required.

Then comes the identification of the *types of loads* that the bolted joint is subjected to. These may be in the form of *axial* or *transverse* loads, or a combination of them, and the amount of *initial tightening*. The user has the opportunity to further communicate

information regarding *coefficients of friction* and the type of connection, indicating whether it is of the *through bolt* type or a *stud* type of connection. Specification or selection of the *materials* for each of the *bolt*, *washer* and *the members* that are being joined caps the input data.

Fig. (7a) : Input screen for the case of axial loading with subsequent tightening.

Invoking next the *Solve* command, the software presents a *Report* comprising a summary of *stresses* (including initial tightening and its effects), *stiffnesses* and *factors of safety*, and a detailed summary of the *fastener geometry and properties*.

It is expected that students of engineering as well as practicing design engineers will find *Bolts* to be an effective tool that makes the accurate analysis and design of bolted connections a breeze.

Acknowledgement

This work was sponsored by King Abdulaziz University, Jeddah, Saudi Arabia under contract no. 102/422.

References

- [1] Fukuoka, Toshimichi; Takaki, Tomohiro, Elasto-plastic analysis of bolted joint during tightening process, American Society of Mechanical Engineers, Design Engineering Division (Publication) DE. v **105** 1999, p 151-156.
- [2] Zhao, Yonglu; Lee, Chu Hwa; Che, Xiangdong; Yee, Cecilia, Prediction of stabilizer bar retention bracket bolt looseness, American Society of Mechanical Engineers, Pressure Vessels and Piping Division (Publication) PVP. v **382**, 1999, p 161-167.
- [3] Yang, Jun; DeWolf, John T., Relaxation in high-strength bolted connections using galvanized steel, *Journal of Bridge Engineering*. v **5** n **2**, 2000, p 99-106.
- [4] Sergeev, B; Madenci, E; Ambur, DR., Influence of bolt spacing and degree of anisotropy in single-lap joints, *Computers and Structures*. v **76** n **1**, 2000, p 89-103.
- [5] Ellis, FV; Tordonato, Sebastian, Calculation of stress relaxation properties for Type 422 stainless steel, American Society of Mechanical Engineers, Pressure Vessels and Piping Division (Publication) PVP. v **388**, 1999, p 395-403.
- [6] Manuel, Thomas J; Kulak, Geoffrey L., Strength of joints that combine bolts and welds, *Journal of Structural Engineering*. v **126** n **3**, Mar 2000, p 279-287.

- [7] **Ma, Xianghong; Bergman, Lawrence; Vakakis, Alexander**, Identification of bolted joints through laser vibrometry, *Proceedings of SPIE The International Society for Optical Engineering*. v **4072**, 2000. Society of Photo Optical Instrumentation Engineers, Bellingham, WA, USA. p 467-478.
- [8] **Gaul, L; Nitsche, R.**, Friction control for vibration suppression, *Mechanical Systems and Signal Processing*. v **14 n 2**, 2000, p 139-150.
- [9] **Calado, L; De Matteis, G; Landolfo, R.**, Experimental response of top and seat angle semi-rigid steel frame connections, *Materials and Structures*. v **33 n 232** Oct 2000, p 499-510.
- [10] **Bogis, H.A., A. Abou Ezz and M. Akyurt**, A user-friendly software for analysis of strain gauge rosette data, *Proc. STCEX 2000, Riyadh*, 18-22 Nov. 2000, V. **3**, pp 187 - 197, 2000.
- [11] **Bogis, H.A., A. Abou Ezz, M. Akyurt and A.A.A. Alghamdi**, An interactive software for curve fitting, *Proc. 6th Saudi Engineering Conf., KFUPM*, v **4**, pp 27 - 40, 2002.
- [12] **Bogis, H.A., A. Abou Ezz, M. Akyurt and A.A.A. Alghamdi**, An interactive software for the design of power screws, *Proc. STCEX 2002, Riyadh*, pp 197 - 202, 2002a.

تصميم وصلات المسامير باستخدام الحاسوب

هيثم عبد الله بوقس، علي أبو العز، عبد الملك علي الجندي، مهتم أكورت
جامعة الملك عبد العزيز، جدة

المستخلص: برنامج تعليمي لتحليل وتصميم الوصلات الميكانيكية التي تستخدم المسامير والبراغي تحت أحمال موازية لمحور المسمار بعد إتمام ربط الوصلة، أو إلى تحت الأحمال العمودية على محورها، وتعتمد الوصلة في قوتها على الاحتكاك أو إجهاد القص. يقوم المستخدم باختيار مادة المسامير المصنعة طبقاً للمعايير القياسية، وسمك أعضاء الوصلة، وكذلك المواد المصنعة منها، بالإضافة إلى معامل الاحتكاك بين كافة أطراف الوصلة. في الحالات التي تكون فيها الوصلة مصممة لربط غطاء اسطوانات هيدروليكية أو الغلايات فإن بمقدور المصمم أن يحصل على قطر المسمار اللازم بحيث يتم تسريب السائل المضغوط قبل الكسر. يقدم البرنامج تقريراً تفصيلياً عن حالة الوصلة والإجهادات في كافة أجزائها ومعامل الأمان، بالإضافة إلى العزم اللازم لتثبيت الوصلة قبل تحميلها، وكذلك الأطوال القياسية للبراغي المستخدمة.